

Wastewater

16EH Series



Applications

Dewatering, water transfer, effluent and wastewater removal

Features

- Handles liquids and solid waste materials up to 3/4" diameter
- Cast iron pump housings with protective epoxy coating for corrosion and rust resistance
- Oil-filled motor housings for lifetime lubrication and rapid heat dissipation
- Stainless steel screws, bolts and lifting ring
- Mechanical seal (stainless steel spring, nitrite parts, carbon and ceramic faces) for long life and reliability
- Secondary exclusion seal to help protect mechanical seal
- High speed, 3450 RPM, 1 HP, ball bearing motor and thermal overload protection
- Permanent split capacitor design
- Capacitor and power cord connections isolated from oil-filled housing for ease of field maintenance
- Dynamically balanced two vane non-clogging impeller with pump-out vanes extend life of pump

Dimensional Outline

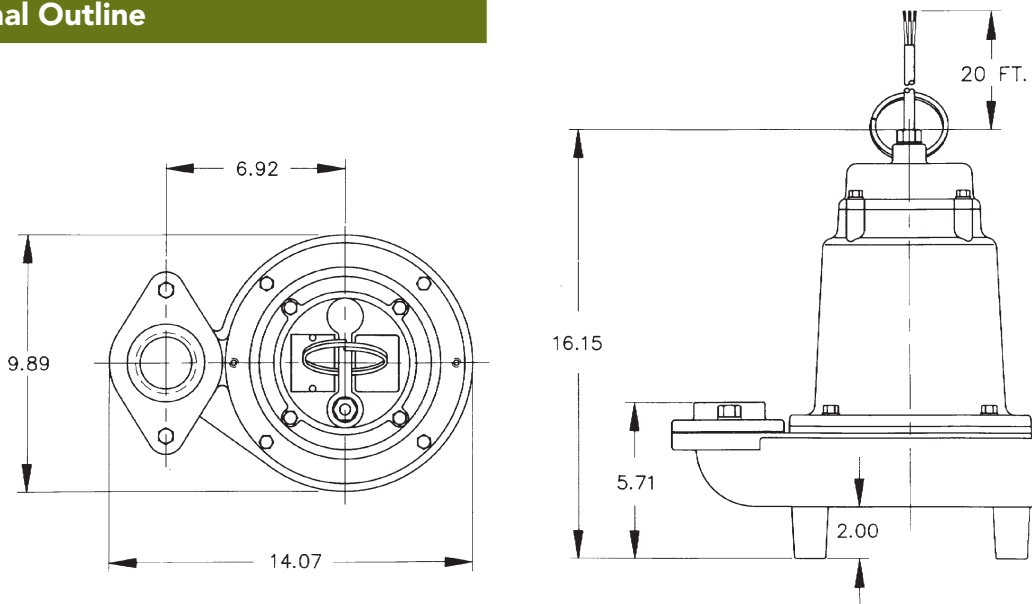

Specifications

Model No.	Item No.	Discharge	Solids Size (dia. in.)	Listing	HP	Volts	Phase	Hz.	RPM	Amps/Watts	Shutoff		Cord Length (ft.)	Weight (lbs.)
											Ft.	P.S.I.		
16EH-CIM	514520*	2" FNPT	3/4	UL/CSA	1	230	1	60	3450	10.2/2200	81	35.1	20	82
16EH-CIM	514530*	2" FNPT	3/4	UL/CSA	1	208-240	3*	60	3450	6.6/1350	81	35.1	20	82
16EH-CIM	514540*	2" FNPT	3/4	UL/CSA	1	460	3*	60	3450	3.2/1350	81	35.1	20	82
16EH-CIM	514550	2" FNPT	3/4	CSA	1	575	3*	60	3450	2.5/1350	81	35.1	20	82

*without plug

*3 phase pumps require a control panel for operation

Construction

Motor Housing	Epoxy-coated cast iron
Impeller Material	Epoxy-coated cast iron
Impeller Type	Non-clog
Volute	Epoxy-coated cast iron
Power Cord	16/3, STW
Mechanical Shaft Seal	Carbon/Ceramic
Fasteners	Stainless steel
Shaft	Stainless steel
Bearings	Upper and lower ball bearings

Performance Data

