

Observer 200 - Alarm System

The OBSERVER 200 alarm system is designed to monitor liquid levels in sump basins, holding tanks, lift station tanks and many other non-potable water and wastewater applications.

This alarm comes standard with a Normally Open, 15 foot float switch to monitor for High Water levels. An optional Normally Closed float switch can be supplied for monitoring Low Water Levels.

The OBSERVER 200 is designed to sound an audible horn and illuminate a visible red light to notify of an alarm situation. There is a green power indicator light to show unit is functioning as well as a silence switch to turn horn off while fixing the alarm situation (the red alarm light will remain on until the alarm conditions are remedied).

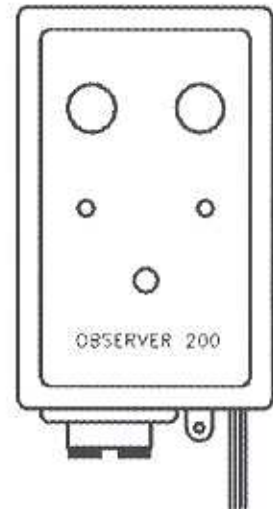

OPTIONS: Alternate float switches with variable cord lengths are available.

Indoor High Water Alarm with Battery Back-Up

Benefits / Features

- Durable Nema 1 thermoplastic enclosure rated for indoor use
- Flashing red “alarm” light, green “on” light and 85 decibels horn at 10 feet
- Mechanical alarm float switch included (15’cord)
- Alarm test and horn silence button with auto reset – 115v
- The alarm will continue to work even when the primary power fails due to battery back-up feature
- Mounting screws, anchors and spade connections included
- Auxiliary dry contacts are standard
- External quick connect terminal block for easy float installation
- UL listed alarm system
- Two-year limited warranty

Specifications

- Dimensions	6” X 3 ¼” X 2 ½”
- Enclosure	Nema 1 thermoplastic (external mounting feet)
- Horn	85 db at 10’
- Weight	2.5 lbs with float
- Voltage	Primary: 120 volt, 12 VAC secondary, 60 Hz (alarm condition 2.5 watts max)
- Power cord	6 feet 120 VAC
- Float switch	15’ mechanical float.
- Float switch connection	Quick connect float connection. Do not apply power. Class Two Output, 12 VAC
- Standard auxiliary contacts	120 VAC, 5 amps max / 60 Hz

OBSERVER 200

ALARM SYSTEM INSTALLATION INSTRUCTIONS

Be sure to follow National Electric Code, ANSI/NFPA 70, when installing this unit to prevent moisture from entering or building up inside equipment.

ALARM & FLOAT INSTALLATION:

1. Decide indoor mounting location.
2. Install a mounting screw in the wall at the desired height and slip keyhole on the back of the box onto the screw and pull down.
3. Use another screw to fasten bottom mounting cleat to the wall.
4. Next, strip the insulation away from the end of the float cord (figure 1). Then push one tab at a time on the bottom of the alarm and insert the bare lead into the labeled quick connect holders.
5. Use the tie strap supplied in the box to secure the float switch (figure 2) at the desired warning level in the tank. Cut off excess material left from the tie strap and discard.
6. Hook the 120 VAC plug into a 120 VAC receptacle separate from the one used for the pump to ensure proper notification.
6. Now manually test the alarm by tilting the float switch up until you hear the alarm notification and you see the alarm light turn on.
7. Periodically test unit by pushing the test button on the cover to make sure unit is working properly.

Figure 1

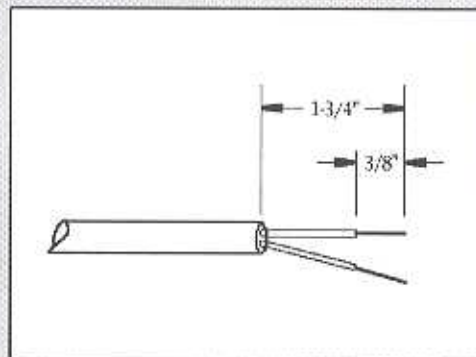
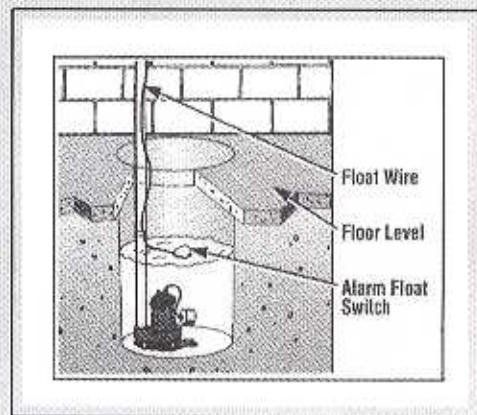

Figure 2



WARNING: FAILURE TO FOLLOW INSTRUCTIONS MAY RESULT IN SERIOUS PERSONAL INJURY OR DEATH. REFER TO THESE INSTRUCTIONS ANY TIME UNIT IS DISCONNECTED FOR ANY REASON.

⚠ WARNING

ELECTRICAL SHOCK HAZARD

Disconnect power before installing or servicing this product. A qualified service person must install and service this product according to applicable electrical and plumbing codes.



⚠ WARNING

EXPLOSION OR FIRE HAZARD

Do not use this product with flammable liquids. Do not install in hazardous locations as defined by National Electrical Code, ANSI/NFPA 70.

