

Aira-Guard™ Air Loss Alarm

Rated Type 3R, Outdoor Alarm Panel



TECHNICAL DATA SHEET

DESCRIPTION OF OPERATION



The Aira-Guard™ Air Loss Alarm is an outdoor rated alarm panel, powered by 120VAC with conduit connections (required). The alarm includes a built-in air pressure switch to monitor the air pressure from the air compressor from an Aerobic Treatment Unit. When powered, the green LED will illuminate inside the top cover of the enclosure to indicate the unit is powered on and that air from the air compressor is at a normal pressure (psi) level. If the air compressor fails or the air tube is broken, the pressure switch will close to activate the alarm. During an alarm condition, the red alarm flashing LEDs will illuminate and the buzzer will annunciate. The alarm condition will stay on until the air sensor senses the correct air pressure from the air compressor. If the test/silence pushbutton is pressed during an alarm condition, it will silence the buzzer and the red alarm LEDs will stop flashing and remain solid. The silence condition will reset when the sensor deactivates. If the alarm is in silence mode for longer than 24 hours, the alarm will reactivate.

Use the auxiliary contacts to connect to building automation systems (BAS) and phone dialers.

STANDARD FEATURES

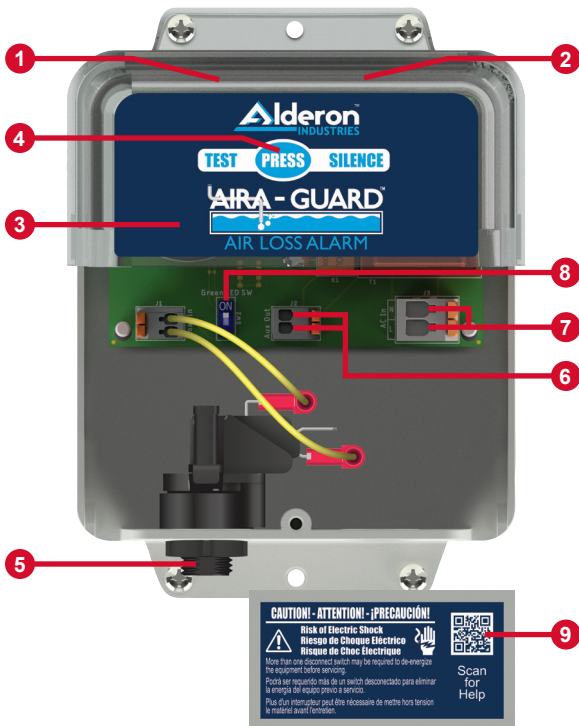

(1) **Power On Indicator** - Green LED illuminates the top cover of the enclosure to indicate the power is on.

(2) **Alarm Beacon** - During an alarm condition, the red alarm LEDs will illuminate, flashing inside the top cover of the enclosure.

(3) **Alarm Buzzer** - The alarm buzzer will annunciate in addition to the visual indication provided by the red LEDs during an alarm condition.

(4) **Test/Silence Pushbutton** - This button may be used to either test or silence the alarm. Testing will activate the alarm beacon and buzzer. During an alarm condition, it will silence the buzzer and the red LEDs will stop flashing and remain solid.

(5) **Air Pressure Switch** - Detects air compressor failure.

(6) **Auxiliary Contacts** - Interface with an external device. The contacts are rated for 24VDC at 0.5A maximum.

(7) **Power Mains Input** - Terminals for L1 and N to connect 120VAC power.

(8) **Power Indicator Turn Off** - Flip switch down to turn off green power LED. Reverse process to turn power indicator back on, flip switch up.

(9) **QR Code** - Scan code which directs you to alderonind.com where additional information can be found for the VersAlarm™ I/O.

SPECIFICATIONS

Aira-Guard™ Air Loss Alarm, Panel Only

**Primary Power**

120VA, 50/60 Hz

Auxiliary Contacts

24VDC at 0.5 Amps maximum

Power

2.64 Watts maximum
(alarm condition)

Enclosure

Type 3R, Outdoor

Certifications

FCC Part 15 (US and Canada)
CSA (US and Canada)

Three-Year Limited Warranty

MECHANICAL DRAWING

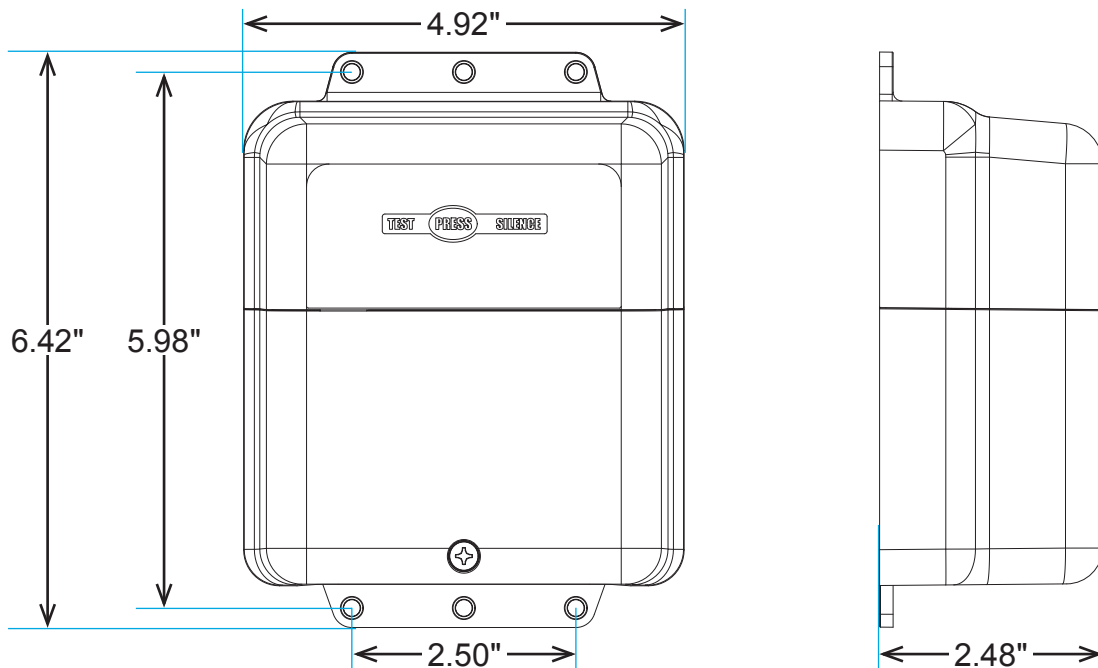

ORDERING INFORMATION

For a complete list of standard products with pricing, refer to the current year price sheet or visit alderonind.com for more information.

PART NUMBER	DESCRIPTION (Alarm Panel includes: Auto Reset and Auxiliary Contacts)
2012958	Aira-Guard™ Air Loss Alarm, 120VAC