

# EFFLUENT PUMPS

## Model: EP50



### Features

- Heavy duty cast iron construction
- Oil-filled continuous duty rated PSC motor
- 2-Vane Closed, cast iron impeller
- Upper and lower ball bearing design
- 3/4" solids handling
- 2" NPT discharge

### Specifications

Physical Data:	
DISCHARGE SIZE	2" NPT
IMPELLER TYPE	2-Vane Cast Iron Closed
CABLE LENGTH	20'
Liquid Handling:	
MAXIMUM LIQUID TEMP.	104°F – Intermittent
ACCEPTABLE PH RANGE	6-8
Temperature:	
MAXIMUM STATOR	120°C
Technical Data:	
POWER CORD TYPE	SOW
SENSOR CORD TYPE	SOW
MOTOR HOUSING	Cast Iron
CASING	Cast Iron
IMPELLER	Cast Iron
MOTOR SHAFT	SS416
HARDWARE	SST
"O" RINGS	NBR
MECHANICAL SEAL	Single Mechanical, Carbon Ceramic
UPPER BEARING	6203
LOWER BEARING	6203

### Specifications

MODEL	HP	HZ	VOLTS/PH	RPM	FULL LOAD AMPS	NEMA START CODE	CORD TYPE	CORD SIZE	CORD O.D.	BREAKER SIZE	RUN CAPACITOR
EP50M1-20	1/2	60	115/1	3450	12.0	J	SOW	16AWG/3C	0.385-0.430	15A	370V 35MFD±5%
EP50M2-20	1/2	60	230/1	3450	6.0	J	SOW	16AWG/3C	0.385-0.430	10A	370V 35MFD±5%
EP50M3-20	1/2	60	230/3	3450	3.2	J	SOW	16AWG/4C	0.410-0.460	5A	N/A
EP50M4-20	1/2	60	460/3	3450	1.6	J	SOW	16AWG/4C	0.410-0.460	3A	N/A
EP50M5-20	1/2	60	208/1	3450	6.5	J	SOW	16AWG/3C	0.385-0.430	10A	450V 35MFD±5%
EP50M6-20	1/2	60	208/3	3450	3.5	J	SOW	16AWG/4C	0.410-0.460	5A	N/A

## Features

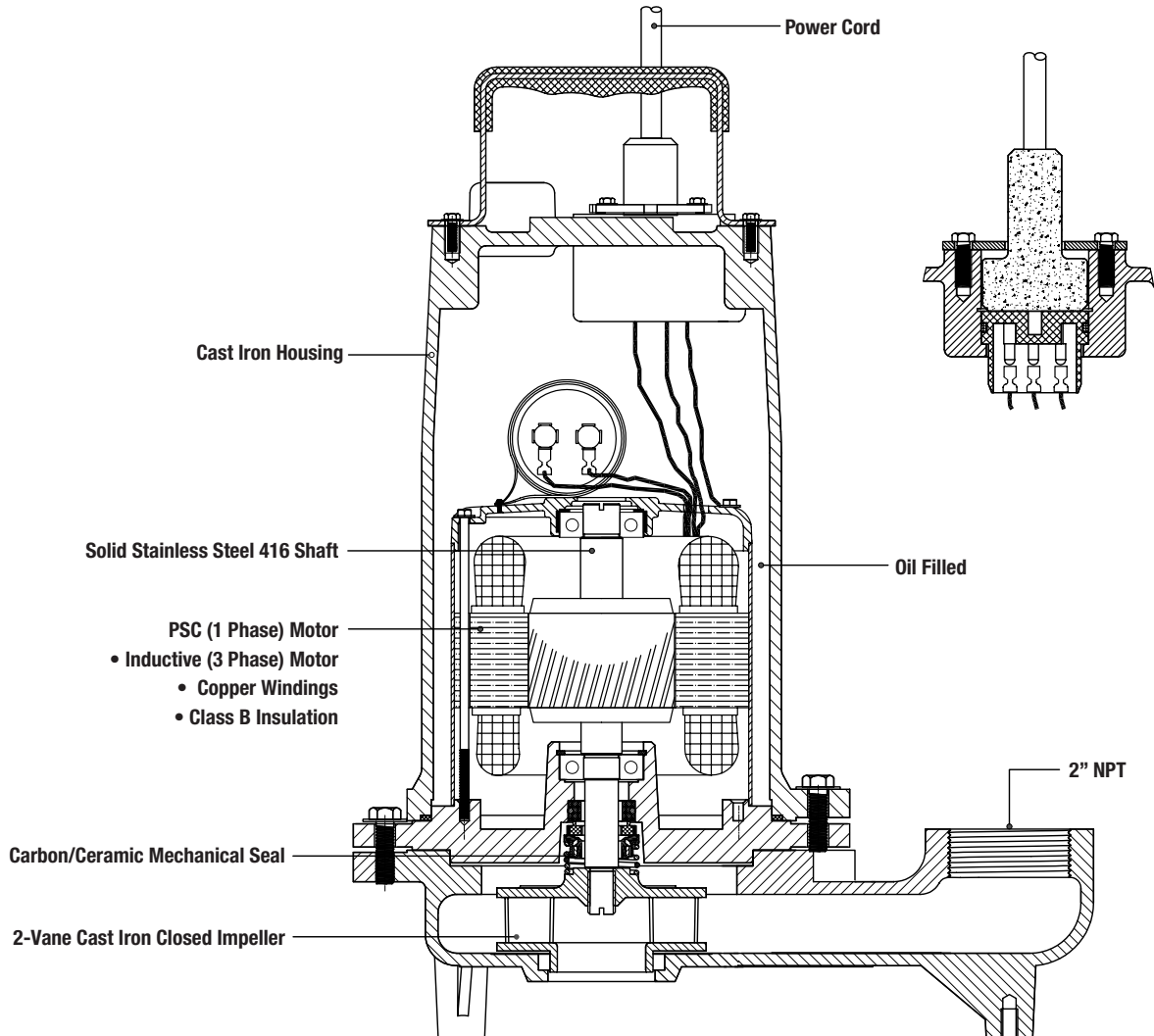

## Dimensions

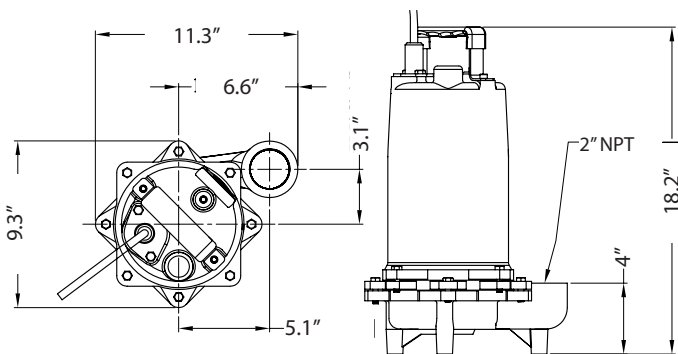

## Performance Curve

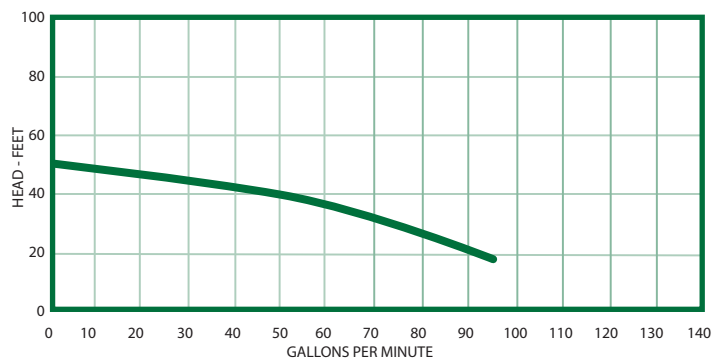

**Ashland**

P U M P

*Honest, Professional, Dependable*

1899 Cottage Street, Ashland, Ohio 44805

Telephone: 855 281-6830 · Fax: 877 326-1994 · ashlandpump.com