

Ashland

P U M P

SPV50 CAST IRON SUMP PUMP

FEATURES

- Heavy duty cast iron construction
- Oil-filled continuous duty PSC motor
- Lower ball bearing construction for smoother operation
- Automatic operation with integrated float switch

*Honest
Professional
Dependable*

1899 Cottage Street, Ashland, Ohio 44805
Telephone: 855 281-6830 · Fax: 877 326-1994
ashlandpump.com



SPV50 - 1/2 HP Cast Iron Sump Pump

TECHNICAL DATA

Physical Data:

DISCHARGE SIZE **1-1/2" NPT**
 IMPELLER TYPE **6-Vane - Cast Iron**
 CABLE LENGTH **10'**

Liquid Handling:

SOLIDS SIZE **1/2"**
 MAXIMUM LIQUID TEMP. **104°F - Intermittent**
 ACCEPTABLE PH RANGE **6-8 PH**

Temperature:

MAXIMUM STATOR **120°C**

Technical Data:

POWER CORD TYPE **SJTW 18/3C**
 MOTOR HOUSING **Cast Iron**
 CASING **Cast Iron**
 IMPELLER **Cast Iron**
 MOTOR SHAFT **Carbon Steel**
 HARDWARE **SST**
 "O" RINGS **NBR**
 SEAL **Single Mechanical Carbon Ceramic**
 UPPER BEARING **Sleeve Bearing**
 LOWER BEARING **6201-RS**

ELECTRICAL DATA

R.P.M. **1750**
 MOTOR TYPE **PSC**
 GEN INSULATION CLASS **B**
 STATOR WINDING CLASS **B**
 MAXIMUM STATOR TEMP **120°C**
 VOLTAGE TOLERANCE **±10%**
 MOTOR PROTECTION **Thermally Protected**
 HP **1/2**
 VOLTAGE **115**
 PHASE **1**
 SERVICE FACTOR **1**
 FULL LOAD AMPS **10.0**

DIMENSIONAL DATA

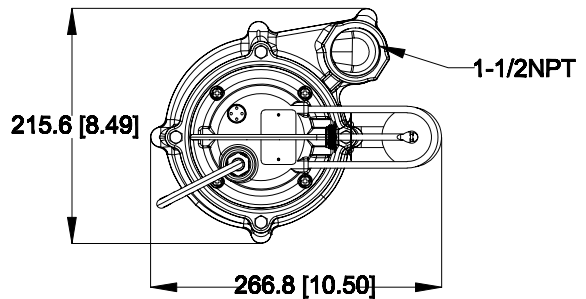
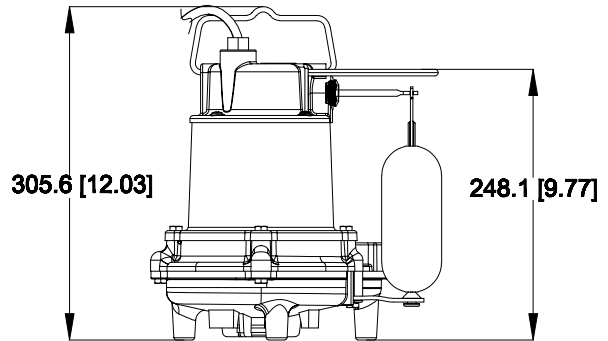

PERFORMANCE CURVE

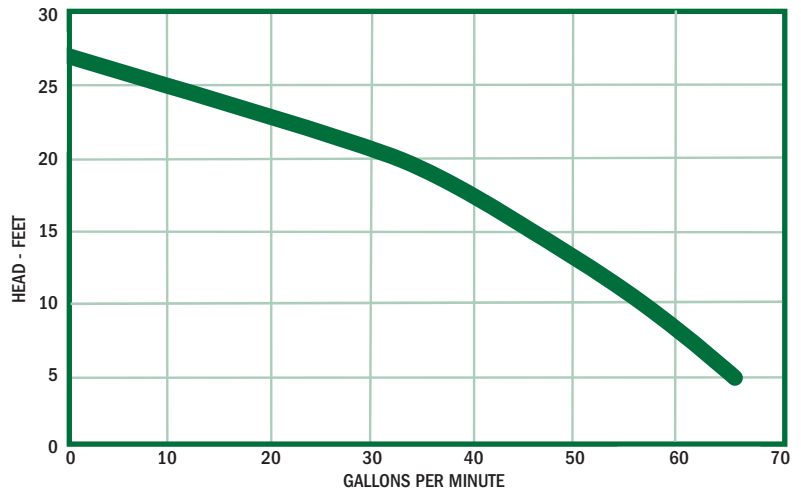

PERFORMANCE CHART

Total Lift(feet)	5	10	15	20	25	27
GPM	65	58	46	32	10	0



P U M P

Honest, Professional, Dependable

1899 Cottage Street, Ashland, Ohio 44805
 Telephone: 855 281-6830 · Fax: 877 326-1994 · ashlandpump.com