



## **B50 CAST IRON SUMP PUMP**

### **FEATURES**

- Heavy duty cast iron construction
- Oil-filled continuous duty PSC motor
- Upper and lower ball bearing construction for smoother operation
- Multiple switch variations with piggyback plug standard

***Honest  
Professional  
Dependable***

1899 Cottage Street, Ashland, Ohio 44805  
Telephone: 855 281-6830 · Fax: 877 326-1994  
[ashlandpump.com](http://ashlandpump.com)



# B50 - 1/2 HP Cast Iron Sump Pump

## TECHNICAL DATA

### Physical Data:

DISCHARGE SIZE **1-1/2" NPT**  
 IMPELLER TYPE **10-Vane - Plastic**  
 CABLE LENGTH **10'**

### Liquid Handling:

SOLIDS SIZE **1/4"**  
 MAXIMUM LIQUID TEMP. **104°F - Intermittent**  
 ACCEPTABLE PH RANGE **6-8 PH**

### Temperature:

MAXIMUM STATOR **120°C**

### Technical Data:

POWER CORD TYPE **SJTW 18/3C**  
 MOTOR HOUSING **Cast Iron**  
 CASING **Thermoplastic**  
 IMPELLER **Thermoplastic**  
 MOTOR SHAFT **SS430**  
 HARDWARE **SST**  
 "O" RINGS **NBR**  
 SEAL **Single Mechanical Carbon Ceramic**  
 UPPER BEARING **608-2RS**  
 LOWER BEARING **6202**

## ELECTRICAL DATA

R.P.M. **3450**  
 MOTOR TYPE **PSC**  
 GEN INSULATION CLASS **B**  
 STATOR WINDING CLASS **B**  
 MAXIMUM STATOR TEMP **120°C**  
 VOLTAGE TOLERANCE **±10%**  
 MOTOR PROTECTION **Thermally Protected**  
 HP **1/3**  
 VOLTAGE **115**  
 PHASE **1**  
 SERVICE FACTOR **1**  
 FULL LOAD AMPS **7.0**

## DIMENSIONAL DATA

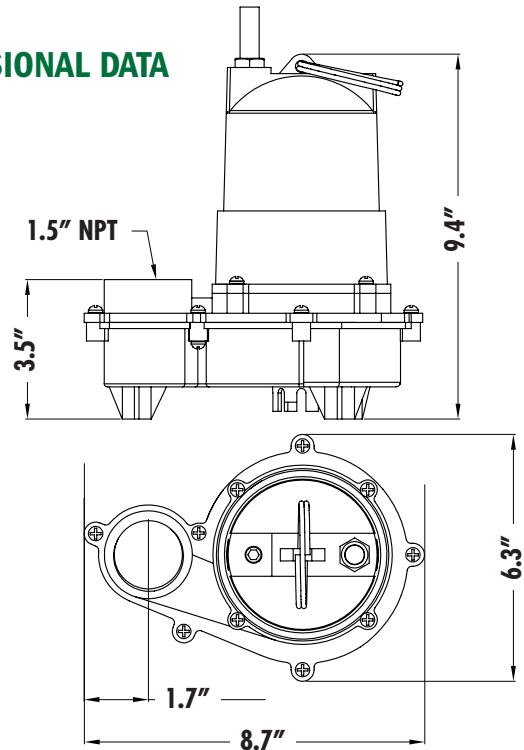

## PERFORMANCE CURVE

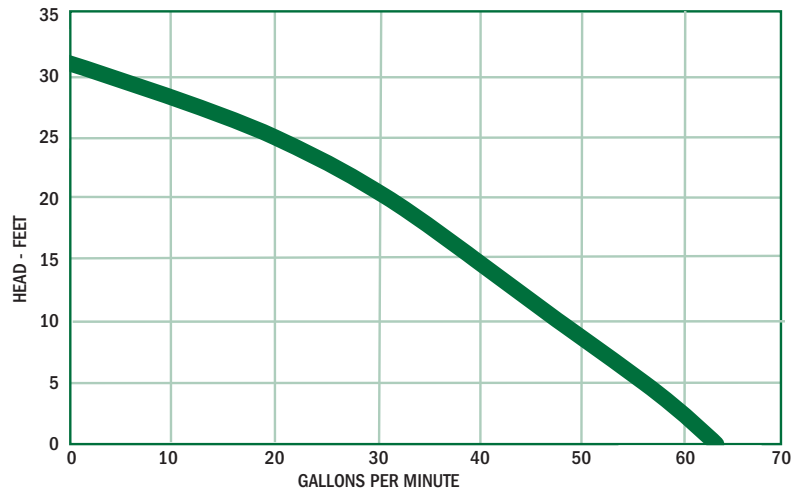

## PERFORMANCE CHART

Total Lift(feet)	0	5	10	15	20	25	30	31
GPM	62	56	47	39	31	20	4	0



P U M P

*Honest, Professional, Dependable*

1899 Cottage Street, Ashland, Ohio 44805  
 Telephone: 855 281-6830 · Fax: 877 326-1994 · ashlandpump.com