

# Legend

---	Field Wiring
---	Field Supplied
SW1	Alarm Test Switch
SW2	Silence Switch
M	Magnetic Contactor
LT	Beacon
B	Buzzer
GND	Ground Lug
CB	Circuit Breaker
TB	Terminal Block
UI	Check-It Board

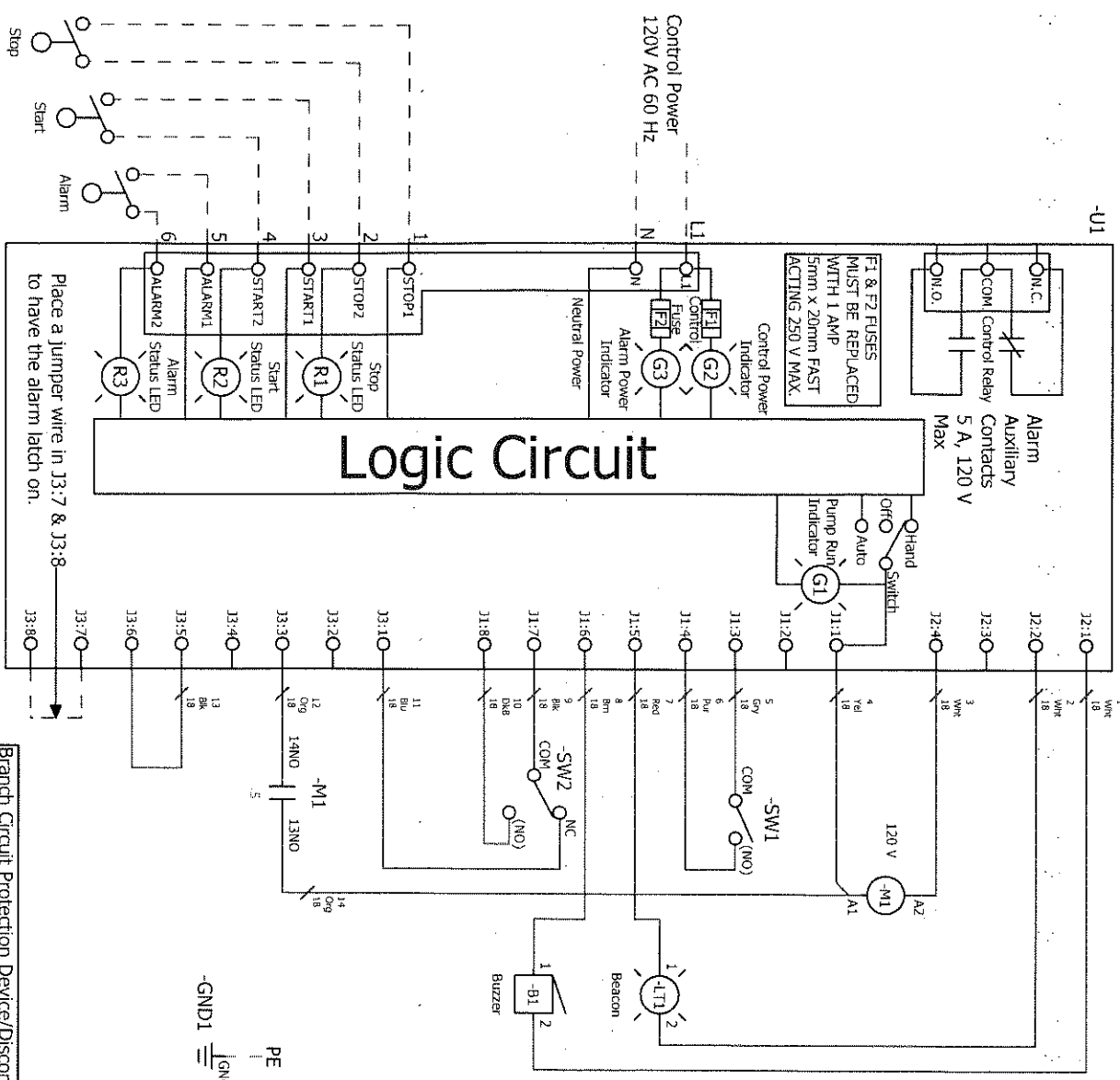

Place a jumper wire in J3:7 & J3:8 to have the alarm latch on.

Branch Circuit Protection Device/Disconnect Means Field Provided -  
Size per manufacturing specifications for Pump/Motor

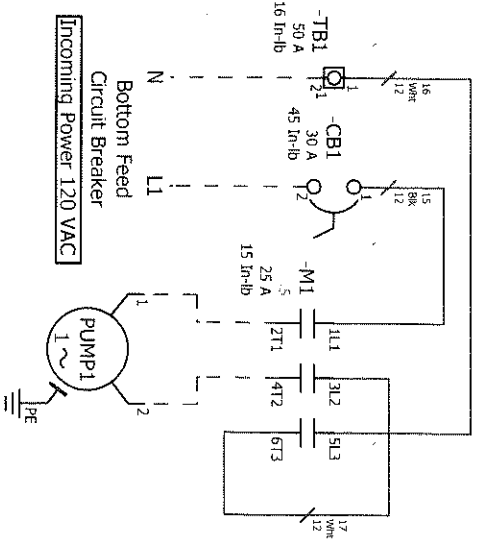

Pump Load 120 VAC 20A 60 Hz  
Pump must contain integral thermal overload protection.  
Ground Motor PE to Ground Lug