

## PIT+PLUS® SR - PREMIUM SIMPLEX SYSTEMS

### APPLICATIONS

Collection of sewage, drainage or seepage water

### FEATURES

- Roto-molded polyethylene basin 20" x 30" (51 cm x 76 cm)
- Radial rib design for extra strength
- Molded inlet hub
- Molded anti-torque stops
- 360° molded handle
- Integrated anti-floatation collar
- Optional alarm versions
- Pre-assembled
- 40.8 Gallon Basin Capacity
- Functional and aesthetic finish cover
- Pump access cover
- Recessed discharge and vent location
- Independent recessed switch module
- Monolithic molded basin top
- Switch cord grips and locators for directional control
- 4/10 hp or 1/2 hp sewage pump and 1 hp grinder pump options available
- Max liquid temperature rating 135 °F (5 °C)



### SERIES SPECIFICATIONS

Pit+Plus SR Sewage Pump Package System									
Item No.	Model No.	Vent	Discharge	Switch Type	Alarm	HP	Pump Item No.	Pump Model No.	Pump Voltage
509661	9SF2V2D	2"	2"	Float	-	4/10	509413	9SC-CIM	115
509662	9SF2V2DA1	2"	2"	Float	Indoor	4/10	509413	9SC-CIM	115
509685	9SP2V2D	2"	2"	ECM	-	4/10	509413	9SC-CIM	115
511661	10SF2V2D	2"	2"	Float	-	1/2	511432	10SC-CIM	115
511662	10SF2V2DA1	2"	2"	Float	Indoor	1/2	511432	10SC-CIM	115
511685	10SP2V2D	2"	2"	ECM	-	1/2	511435	10SC-CIM	115

Pit+Plus SR Grinder Pump Package System									
Item No.	Model No.	Vent	Discharge	Switch Type	Alarm	HP	Pump Item No.	Pump Model No.	Pump Voltage
509816	16SF2V2D	2"	2"	Float	-	1	509809	16G-M151-20	115

Note: Check valve not included.



### PUMP OPTIONS

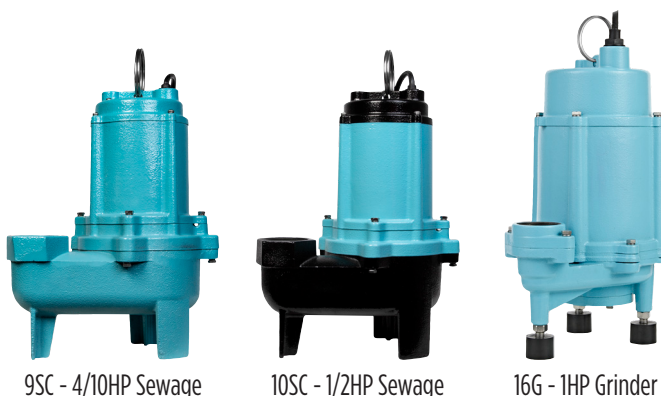

9SC - 4/10HP Sewage

10SC - 1/2HP Sewage

16G - 1HP Grinder

Basin Assemblies			
Item No.	Model No.	Vent	Discharge
513611	PPS2V2D	2"	2"
513612	PPS2V3D	2"	3"
513613	PPS3V3D	3"	3"
513614	PPS3V2D	3"	2"

Note: Pump and switch assembly not included.

Replacement Cover and Hardware Kits	
Item No.	Description
113388	Includes replacement bolts, washers, gasket, and wing bolts for finish cover
113389	Includes replacement main basin cover, bolts, washers, gasket, and wing bolts for finish cover

# PIT+PLUS® - PREMIUM SIMPLEX SYSTEMS

## ENGINEERING DATA

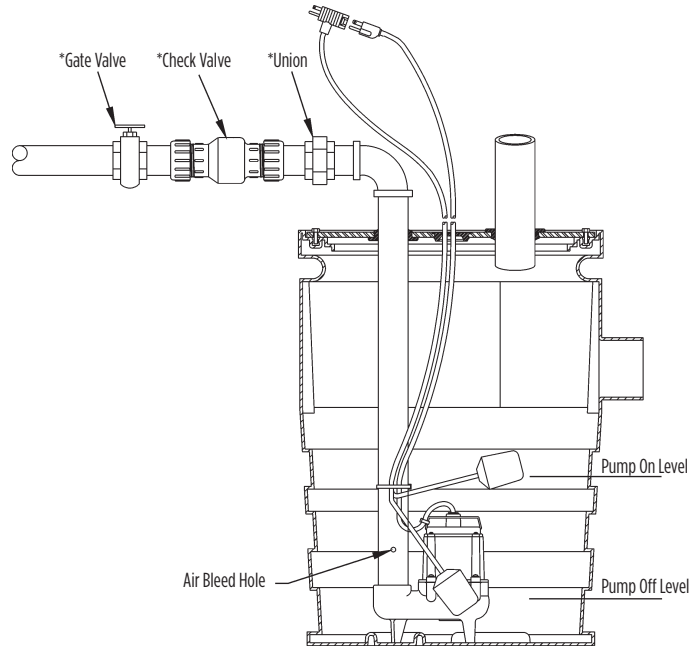
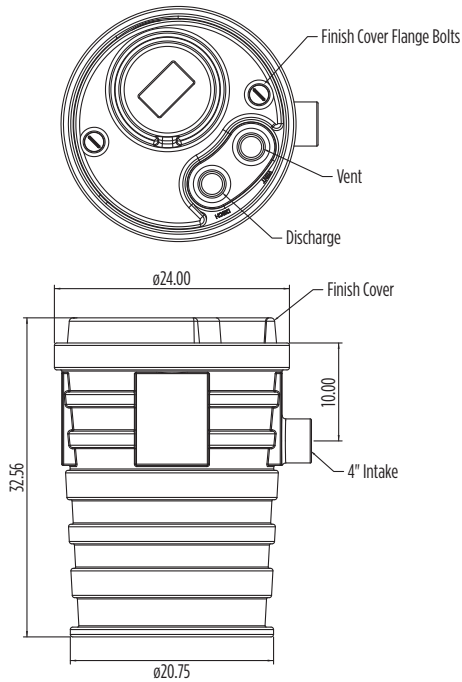

## PERFORMANCE DATA

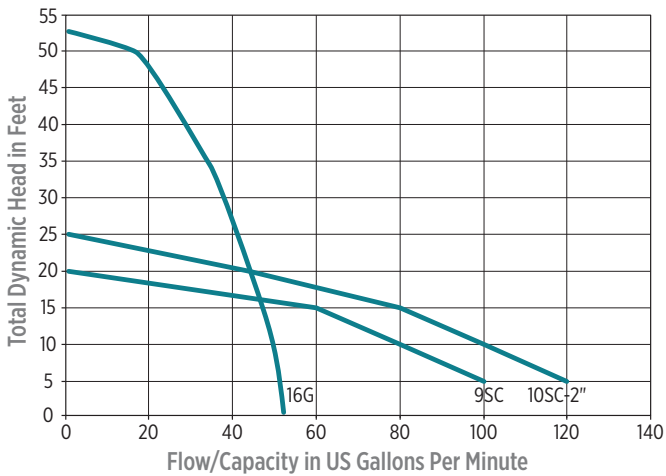

## FLOAT AND ECM™ ASSEMBLIES



Float Assemblies		
Item No.	Model No.	Description
513631	PPSFNA	Senior Float Assy, No Alarm Hardware
513632	PPSFWA	Senior Float Assy, W/Alarm Hardware

ECM™ Assemblies		
Item No.	Model No.	Description
513635	PPSENA	Senior ECM Assy, No Alarm Hardware
513636	PPSEWA	Senior ECM Assy, W/Alarm Hardware

Note: Not for use with 1 hp grinder pump