

APPLICATIONS

- Effluent wastewater removal
- Dewatering
- Water transfer

FEATURES

- Permanent Split Capacitor (PSC)
- Designed for continuous duty
- Energy-saving low amp draw
- Cooler running motor
- 1-1/2" FNPT (38 mm) discharge
- Handles solids up to 3/4" (19 mm) diameter
- Multiple switch options for automatic operation
- 140 °F (60 °C) liquid temperature rating
- cCSAus listed



SERIES SPECIFICATIONS

| Volts | Hz | Amps | | Watts | Performance (GPM @ Height in Feet) | | | | | Shut-Off (ft) | PSI |
|---------|----|------|-------|-------|------------------------------------|-----|-----|-----|-----|---------------|------|
| | | FLA | Start | | 5' | 10' | 20' | 30' | 40' | | |
| 115 | 60 | 9 | 16 | 1045 | 70 | 60 | 50 | 30 | 10 | 45 | 19.5 |
| 208-230 | 60 | 9 | 8.2 | 1045 | 70 | 60 | 50 | 30 | 10 | 45 | 19.5 |

| Item No. | Model | HP | Volts | Switch Type/ Operation | On Level | Off Level | Cord | Weight |
|----------|--------------|------|---------|------------------------|---------------------------------|-------------------------------|--------------|--------------------|
| 509239 | 9ENH-CIA-SFS | 4/10 | 115 | Integral Float Switch | 9" - 14" 22.86 cm - 35.56 cm | 2" - 6" 5 cm - 15.24 cm | 20' 6.1 m | 38 lbs 17.24 Kg |
| 509240 | 9ENH-CIA-SFS | 4/10 | 115 | Integral Float Switch | 9" - 14" 22.86 cm - 35.56 cm | 2" - 6" 5 cm - 15.24 cm | 30' 9.1 m | 39 lbs 17.69 |
| 509233 | 9ENH-CIA-RF | 4/10 | 115 | Piggyback Float Switch | 9" - 12" 22.86 cm - 30.48 cm | 3" - 6" 7.62 cm - 15.24 cm | 20' 6.1 m | 38 lbs 17.24 Kg |
| 509234 | 9ENH-CIA-RF | 4/10 | 115 | Piggyback Float Switch | 9" - 12" 22.86 cm - 30.48 cm | 3" - 6" 7.62 cm - 15.24 cm | 30' 9.1 m | 39 lbs 17.69 |
| 509231 | 9ENH-CIM | 4/10 | 115 | Manual | - | - | 20' 6.1 m | 37 lbs 16.78 Kg |
| 509232 | 9ENH-CIM | 4/10 | 115 | Manual | - | - | 30' 9.1 m | 38 lbs 17.24 Kg |
| 509237 | 9ENH-CIA-RF | 4/10 | 208-230 | Piggyback Float Switch | 9" - 12" 22.86 cm - 30.48 cm | 3" - 6" 7.62 cm - 15.24 cm | 20' 6.1 m | 37 lbs 16.78 Kg |
| 509238 | 9ENH-CIA-RF | 4/10 | 208-230 | Piggyback Float Switch | 9" - 12" 22.86 cm - 30.48 cm | 3" - 6" 7.62 cm - 15.24 cm | 30' 9.1 m | 38 lbs 17.24 Kg |
| 509235 | 9ENH-CIM | 4/10 | 208-230 | Manual | - | - | 20' 6.1 m | 37 lbs 16.78 Kg |
| 509236 | 9ENH-CIM | 4/10 | 208-230 | Manual | - | - | 30' 9.1 m | 38 lbs 17.24 Kg |

ENGINEERING DATA

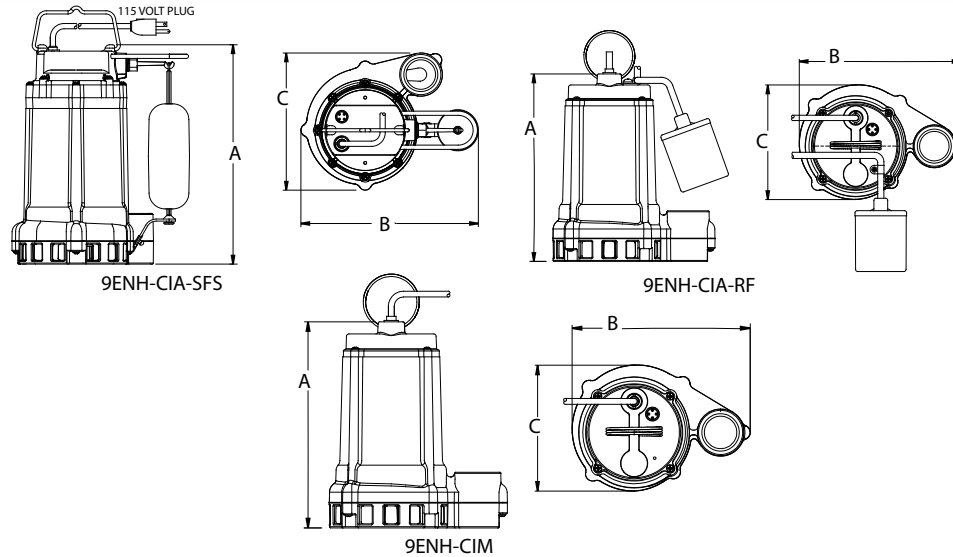

| Model | A | B | C |
|--------------|--------------------|--------------------|-------------------|
| 9ENH-CIA-SFS | 12.9" 32.77 cm | 10.54" 26.54 cm | 8.07" 20.49 cm |
| 9ENH-CIA-RF | 11.03" 28.01 cm | 9.53" 24.21 cm | 6.74" 17.12 cm |
| 9ENH-CIM | 11.03" 28.01 cm | 9.53" 24.21 cm | 6.74" 17.12 cm |

PERFORMANCE DATA

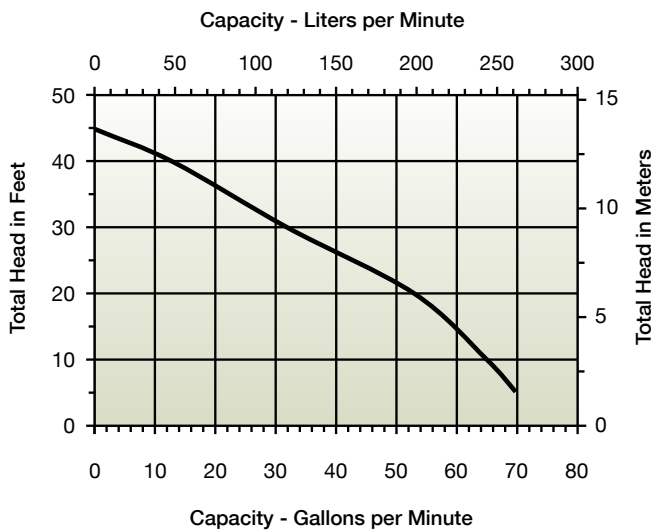

CONSTRUCTION

| | |
|------------------------------|---|
| Cover | Epoxy-coated cast iron/ *Thermoplastic |
| Motor Housing | Epoxy-coated cast iron |
| Impeller Material | Thermoplastic elastomer |
| Impeller Type | Non-clog |
| Volute | Epoxy-coated cast iron |
| Mechanical Shaft Seal | Nitrile with carbon and ceramic faces |
| Fasteners | Stainless steel |
| Shaft | Steel |
| Bearings | Upper and lower ball bearing |
| Power Cord | SJTW **SJTOW |

* On SFS models

** On 30' 9ENH-CIA-RF and 9ENH-CIM models