



SW300 SEWAGE PUMP

FEATURES

- Heavy duty cast iron
- Oil-filled continuous duty motor
- 2 vane cast iron semi-open impeller

*Honest
Professional
Dependable*

1899 Cottage Street, Ashland, Ohio 44805

Telephone: 855 281-6830 · Fax: 877 326-1994

ashlandpump.com



SW300 - 3 HP Submersible Sewage Pump

TECHNICAL DATA

Physical Data:

DISCHARGE SIZE **3" NPT**
 IMPELLER TYPE **2-Vane, Open - Cast Iron**
 CABLE LENGTH **20'**

Liquid Handling:

SOLIDS SIZE **2-1/2"**
 MAXIMUM LIQUID TEMP. **104°F - Intermittent**
 ACCEPTABLE PH RANGE **6-8**

Temperature:

MAXIMUM STATOR **130°C**

Technical Data:

POWER CORD TYPE **SOW 8/4C, SOW 12/4C
 S00W 12/4C**

MOTOR HOUSING **Cast Iron**

CASING **Cast Iron**

IMPELLER **Cast Iron**

MOTOR SHAFT **SS420**

HARDWARE **SST**

"O" RINGS **NBR**

SEALS **Single Mechanical,
 Carbon Ceramic**

UPPER BEARING **6203**

LOWER BEARING **6206**

ELECTRICAL DATA

R.P.M. **1750**

MOTOR TYPE **3PH**

GENERAL INSULATION CLASS **B**

STATOR WINDING CLASS **B**

MAXIMUM STATOR TEMPERATURE **120°C**

VOLTAGE TOLERANCE **±10%**

MOTOR PROTECTION **N/A**

HP **3**

VOLTAGE **230, 460**

PHASE **1, 3**

SERVICE FACTOR **1**

FULL LOAD AMPS **28, 20, 10.5**

DIMENSIONAL DATA

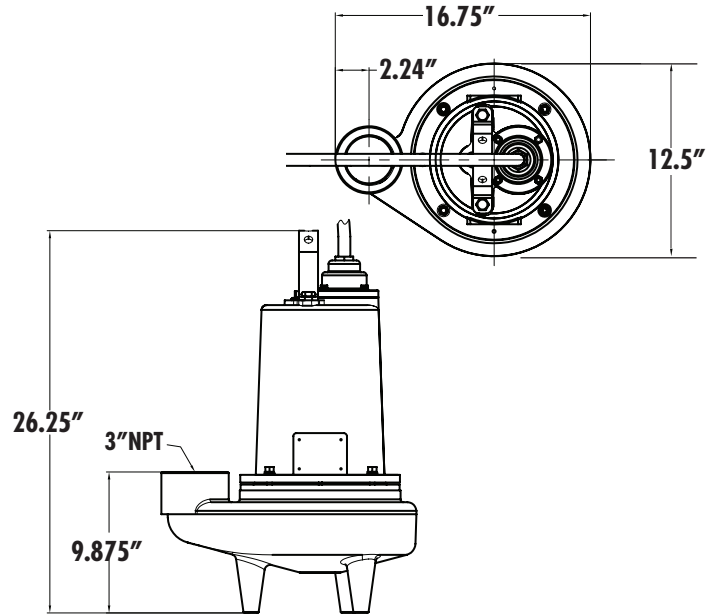

PERFORMANCE CURVE

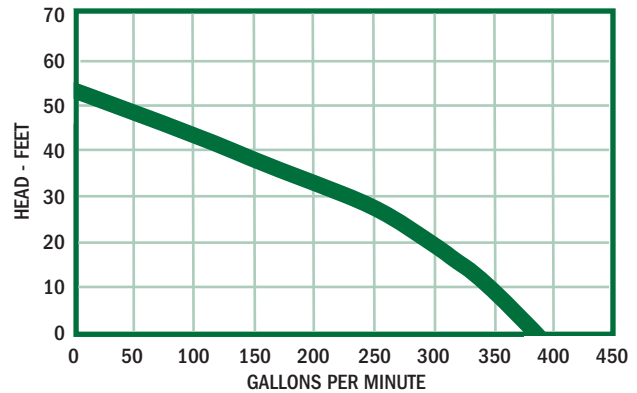

PERFORMANCE CHART

Total Lift(feet)	0	15	20	30	40	53
GPM	370	320	292	225	130	0

Ashland

P U M P

Honest, Professional, Dependable

1899 Cottage Street, Ashland, Ohio 44805

Telephone: 855 281-6830 · Fax: 877 326-1994 · ashlandpump.com