



AGP500 GRINDER PUMP

FEATURES

- Heavy duty grinder family
- Dual seals
- Brass, 10 vane open impeller

***Honest
Professional
Dependable***

1899 Cottage Street, Ashland, Ohio 44805
Telephone: 855 281-6830 · Fax: 877 326-1994
ashlandpump.com



AGP500 - 5 HP Grinder Pump

TECHNICAL DATA

Physical Data:

DISCHARGE SIZE **2-1/2" NPT**
 IMPELLER TYPE **10-Vane, Open - Brass**
 CABLE LENGTH **20'**

Liquid Handling:

SOLIDS SIZE **1/2"**
 MAXIMUM LIQUID TEMP. **140°F - Intermittent**
104°F - Continuous

ACCEPTABLE PH RANGE **6-8**

Temperature:

MAXIMUM STATOR **130°C**
 OIL FLASH POINT **145°C**

Technical Data:

POWER CORD TYPE **SOW**
 MOTOR HOUSING **Cast Iron**
 CASING **N/A**
 IMPELLER **Brass**
 MOTOR SHAFT **SS**
 HARDWARE **SS**
 "O" RINGS **NBR**
 MECHANICAL SEALS **N/A**
 UPPER BEARING **6204**
 LOWER BEARING **6207**

ELECTRICAL DATA

R.P.M. **3450**
 MOTOR TYPE **PSC**
 GENERAL INSULATION CLASS **H**
 STATOR WINDING CLASS **H**
 MAXIMUM STATOR TEMPERATURE **130°C**
 VOLTAGE TOLERANCE **±10%**
 MOTOR PROTECTION **Thermally Protected**
 HP **5**
 VOLTAGE/PHASE/FULL LOAD AMPS **230/1/35.2**
460/3/10.34

DIMENSIONAL DATA

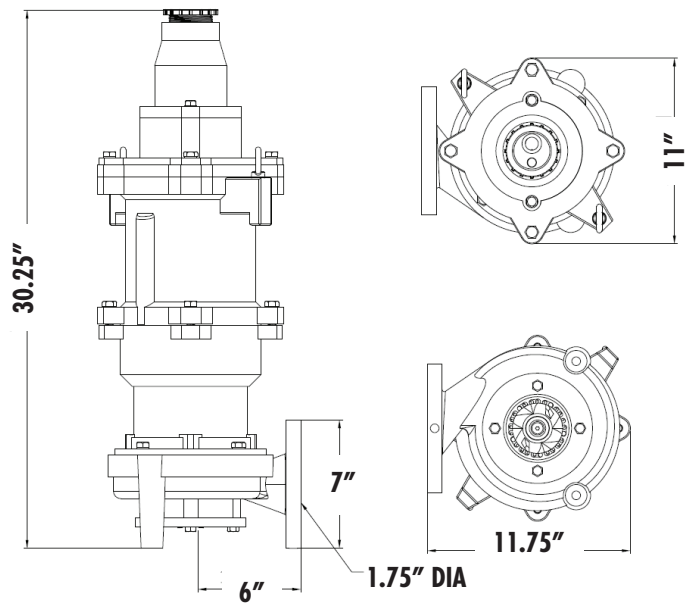

PERFORMANCE CURVE

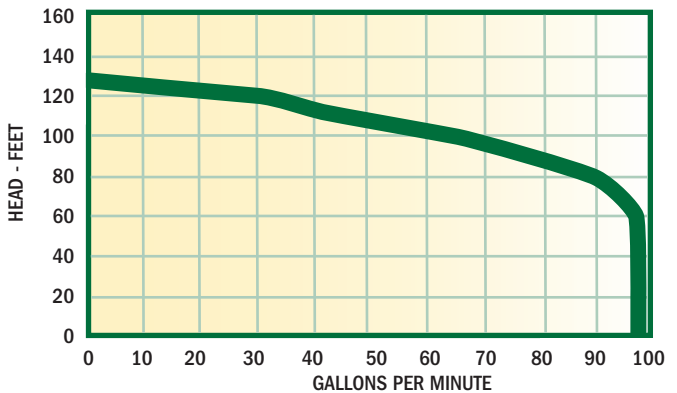

PERFORMANCE CHART

Total Lift (feet)	5	20	40	60	80	100	120	130
GPM	99	99	99	98	90	65	30	0



P U M P

Honest, Professional, Dependable

1899 Cottage Street, Ashland, Ohio 44805
 Telephone: 855 281-6830 · Fax: 877 326-1994 · ashlandpump.com