



MYERS[®]
MW50 SERIES
1/2 HORSEPOWER
2" SOLIDS HANDLING SEWAGE PUMPS



MYERS® MW50 SERIES

Solids Handling Sewage Pumps

The Right Choice

The Myers MW50 Series sewage pumps provide big performance in a small package. The enclosed two-vane impeller provides the flow and head required for residential and light commercial sewage applications, and passes a full 2" diameter solid. The MW50 is constructed of only the highest quality corrosion resistant materials – cast iron, stainless steel and engineered thermoplastics – for many years of service in harsh sewage environment. The MW50 is available in manual models for use with external controls or automatic models with piggyback mechanical float. For more information, call your Myers distributor or the Myers Ohio sales office at 419-289-6898.



Product Capabilities

Capacities To	135 gpm	510 lpm
Heads To	27 ft.	8.23 m
Solids Handling	2 in.	50.6 mm
Liquids Handling	domestic sewage and drain water	
Intermittent Liquid Temp.	140°F	60°C
Motor Electrical Data	1/2 hp, 1625 rpm, PSC 115 volt, 9.0 amp, 1Ø, 60 Hz 230 volt, 4.5 amp, 1Ø, 60 Hz	
Std. Third Party Approvals	CSA, UL	
Acceptable pH Range	6 – 9	
Specific Gravity	.9 – 1.1	
Viscosity	28 – 35 SSU	
Discharge, NPT	2 in.	50.8 mm
Min. Sump Diameter		
Simplex	24 in.	61 cm
Duplex	36 in.	91.4 cm

Note: Consult factory for applications outside these recommendations.

Construction Materials

Motor Housing	cast iron, Class 30, ASTM A48
Motor Bearings	ball bearing-lower, top-sleeve
Enclosed 2-Vane Impeller	engineered thermoplastic
Impeller Wear Ring	304 SST
Volute	thermoplastic
Volute Seal Ring	HUVA cup
Power, Control Cords	16/3 SJTW/SJTW-A
Mechanical Seal	Type 6 - carbon/ceramic
Fasteners	300 Series SST

Pump Features and Applications

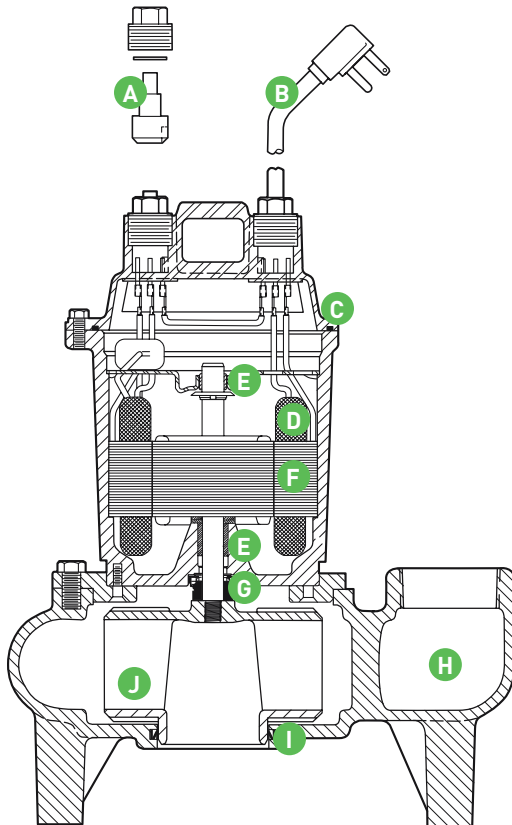

A. Plug

Provides watertight seal.

B. Power Cord

Quick-connect watertight fitting is replaceable from pump exterior.

C. Motor Housing

Cast iron for efficient heat transfer and corrosion resistance.

D. Overload Switch

Built-in to protect against overload conditions.

E. Thrust Washer Sleeve Bearings

Enhance smooth operation and extend pump life.

F. Motor

½ HP, 1625 RPM, 60 Hz, 115 or 230V, PSC single phase. Oil-cooled and lubricated.

G. Rotary Shaft Seal

Carbon, ceramic faces.

H. High Efficiency Volute

Passes 2" spherical solids. 2" NPT discharge.

I. Volute/Impeller Seal Ring

Maintains high efficiency and reduces recirculation. Replaceable.

J. Enclosed Two Vane Impeller

High efficiency, passes 2" spherical solids, with stainless steel wear ring. Engineered thermoplastic.

Mechanical Float Switch

Mercury-free, 90° angle operation. (Piggyback models only.)

Two Vane Impeller Design Provides Maximum Efficiency.

- Enclosed design for high efficiency pump.
- Eliminates possibility of jamming between impeller and volute.
- Passes a full 2 inch solid.
- Original performance can be restored if wear occurs by replacing volute seal ring.

Durable Motor Will Deliver Many Years Of Reliable Service.

- Oil-filled motor for maximum heat dissipation and constant bearing lubrication.
- Permanent split capacitor motor eliminates starting switches and relays which are prone to fail.

The MW50 Is Designed For Many Years Of Maintenance Free Operation.

- Positive sealing, quick connect power cord and piggyback float switch make replacement simple if service is ever necessary.
- Field tested, wide angle, mercury-free mechanical float switch provides maximum draw down. (Automatic models only.)
- Long flexible Type 6 seal provides high pressure sealing with improved seal face protection by location.
- Lower ball bearing eliminates sleeve bearing wear and significantly reduces motor wear.
- Low amp draw from the efficient PSC motor means less heat build-up.

Performance Data and Dimensions [Dimensions in mm]

1625 RPM

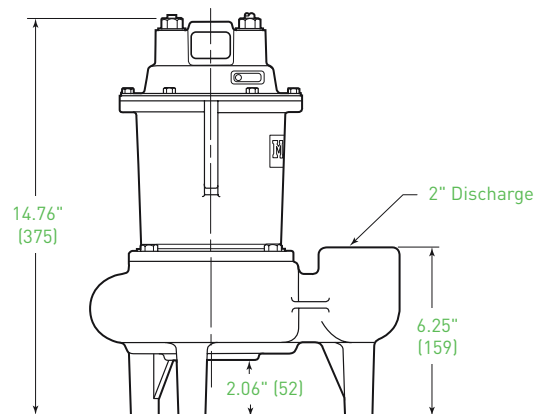
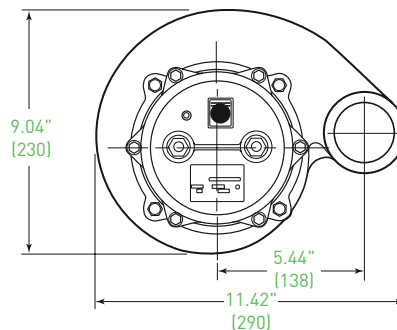
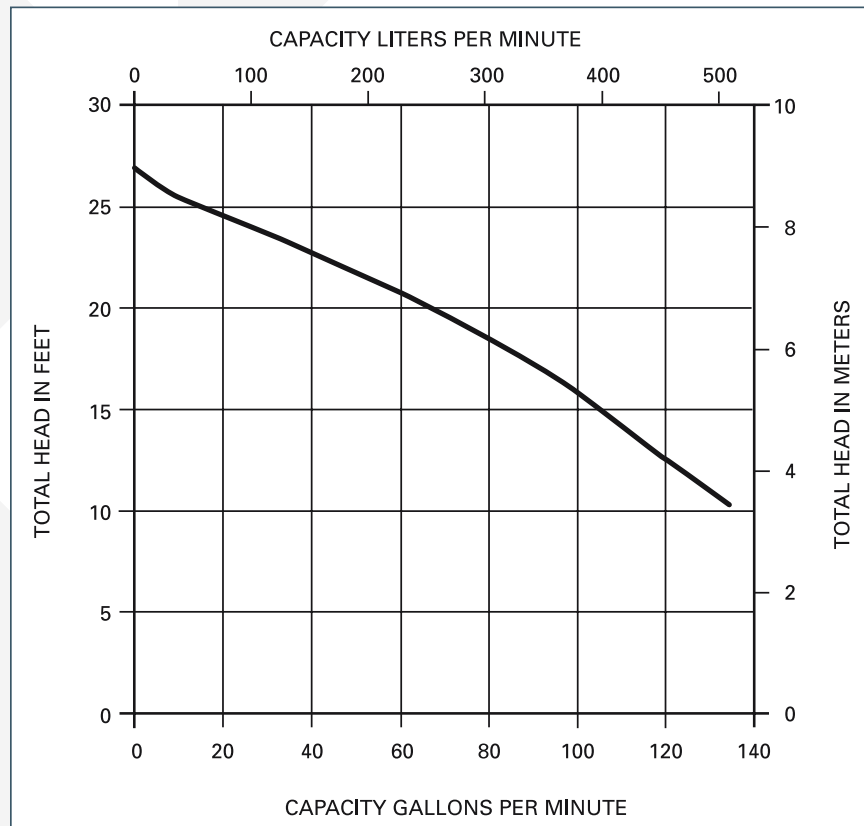

740 EAST 9TH STREET,
ASHLAND, OHIO 44805
WWW.FEMYERS.COM

269 TRILLIUM DRIVE, KITCHENER,
ONTARIO, CANADA N2G 4W5
WWW.FEMYERS.COM

Because we are continuously improving our products and services, Pentair reserves the right to change specifications without prior notice.
K3470 1/7/13 © 2013 Pentair Ltd. All Rights Reserved.